

ASSEMBLED MODEL NO.	PLUNGER PART NO.	CAM STYLE	ASSEMBLED ORIENTATION	NO	QTY	PART NO	DESCRIPTION	SEAL KIT	CLEVIS PIN KIT
LI-4080-10-S-0	81400216	STR	0	1	3	23050045	RING, RTNG, EXT, 0.781		X
LI-4080-10-S-60			60	2	2	23340006	STOCK, CORD, .75 X 1.63, 50, NBR		X
LI-4080-10-S-120			120	3	3	23350087	SPRING, COMPRESSION	X	
LI-4080-10-S-30	81400246	STR	30	4	3	23650011	BALL, TUNGSTEN-CARBIDE, 8mm	X	
LI-4080-10-S-90			90	5	2	39051080	O-RING, (10mm X 1)	X	
LI-4080-10-S-150			150	6	1	39051086	O-RING, (80mm X 2)	X	
LI-4080-10-L-0	81400226	LH	0	7	2	39051088	O-RING, (8mm X 3)	X	
LI-4080-10-L-60			60	8	1	39053047	SEAL, WIPER, SNAP IN, WED, 45, 94A, AU	X	
LI-4080-10-L-120			120	9	1	39056007	SEAL, STEP, ROD, 45	X	
LI-4080-10-L-30	81400256	LH	30	10	1	39056026	SEAL, CAP, PISTON, 80, 90A, AU GRPHT FLD	X	
LI-4080-10-L-90			90	11	2	43068006	PLUG, PORT, HOLLOW HEX, G1/4		
LI-4080-10-L-150			150	12	1	81400156	CAP, LC/SC, 7MPa, 80B		
LI-4080-10-R-0	81400236	RH	0	13	2	81400201	PLUG, MANIFOLD, 7MPa, M10		
LI-4080-10-R-60			60	14	3	81400204	PIN, STOP, BALL, METRIC, 8mm BALL	X	
LI-4080-10-R-120			120	15	1	81400276	PIN, ROCKER, SC, 7MPa, 80B		X
LI-4080-10-R-30	81400266	RH	30	N/A	N/A	L6014800	KIT, SEAL, SC, 7MPa, 80B	NOTED	N/A
LI-4080-10-R-90			90	N/A	N/A	L6214800	KIT, CLEVIS PIN, SC, 7MPa, 80B	N/A	NOTED
LI-4080-10-R-150			150						

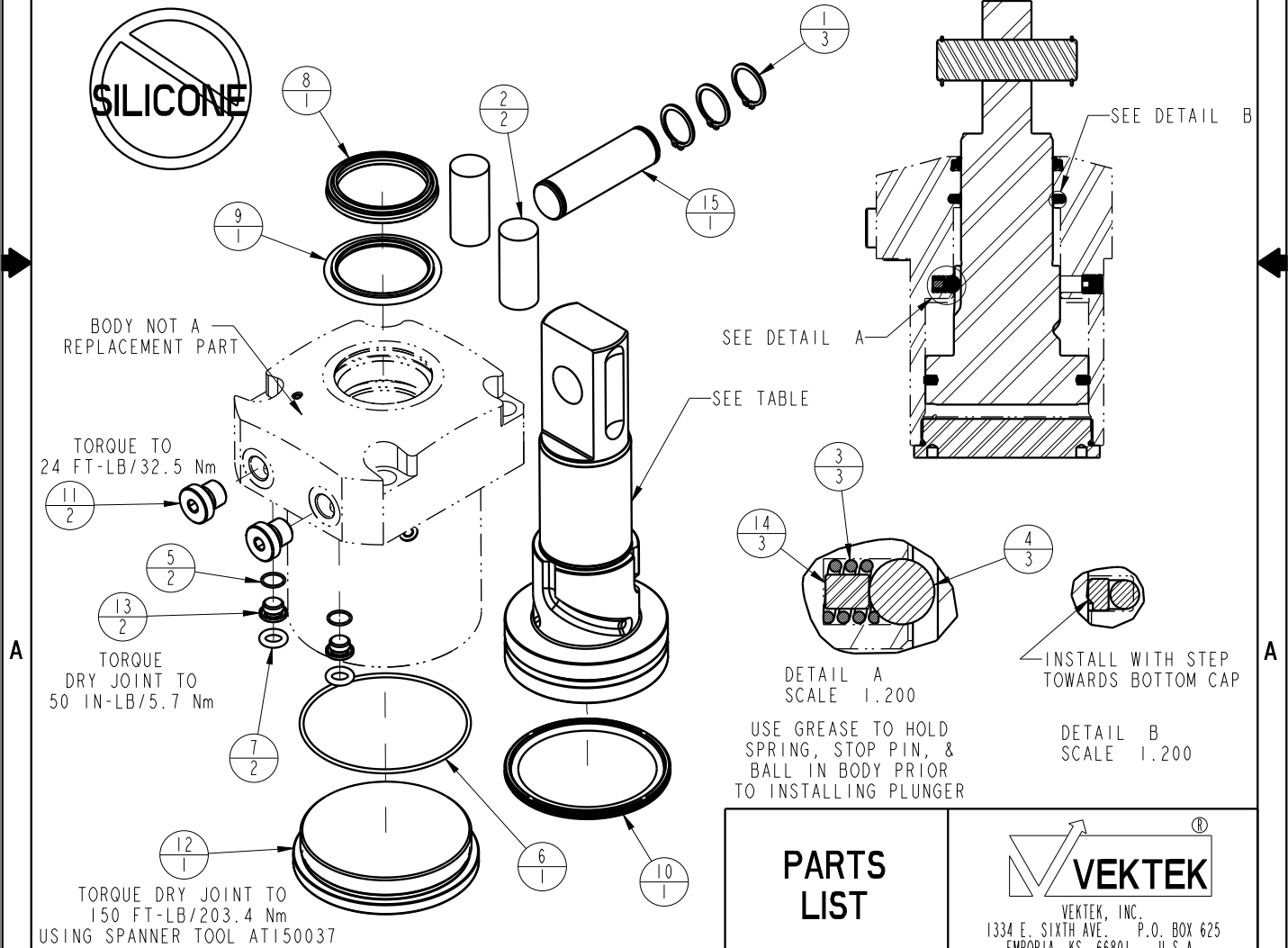

PARTS LIST		VEKTEK	
ASSEMBLIES AFFECTED SEE ASSEMBLY MODEL NO. TABLE ABOVE		VEKTEK, INC. 1334 E. SIXTH AVE. P.O. BOX 625 EMPORIA, KS. 66801 U.S.A.	
SIZE A		LPL1429	REV B

B	3273	RELEASE	JDW	08/15/18
REV	IN ACCORDANCE WITH ECN	EFFECTIVE DATE	REVISED BY	DATE
DRW BY: MAJ	DRAWING STATUS: Released			
DATE: 4-16-15	PRODUCTION APPROVED FOR RELEASED STATUS ONLY			